

**Oil Pan**

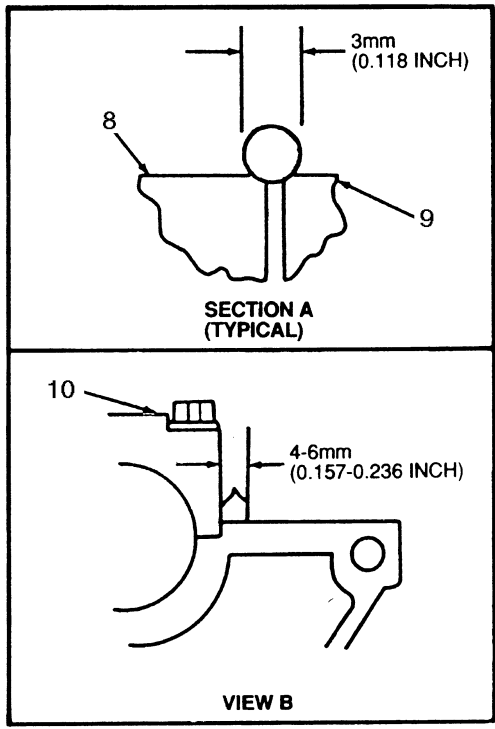
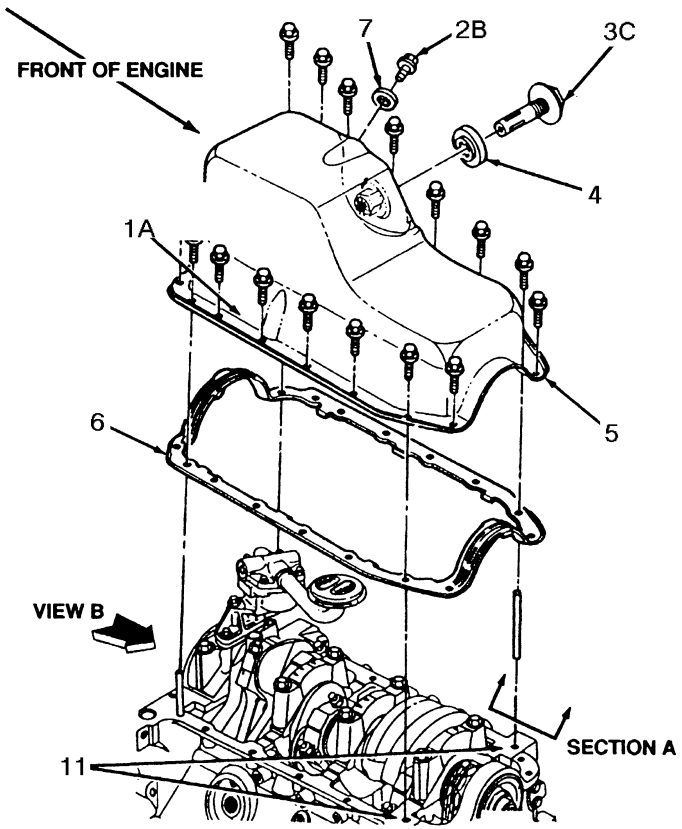

- 1 Bolt (16 req'd)
- 2 Oil pan drain plug
- 3 Low oil level sensor
- 4 Low oil level sensor washer
- 5 Oil pan
- 6 Oil pan gasket
- 7 Oil pan drain plug gasket

- 8 Cylinder block
  - 9 Engine front cover
  - 10 Rear main bearing cap
  - 11 Silicone gasket and sealant (4 places)
- A Tighten to 10-14 Nm (8-10 lb.ft.)  
 B Tighten to 11-16 Nm (9-12 lb.ft.)  
 C Tighten to 27-41 Nm (20-30 lb.ft.)