

● TIGHTEN IN SEQUENCE IN THREE STEPS

○ REFER TO LEGEND

FRONT OF ENGINE

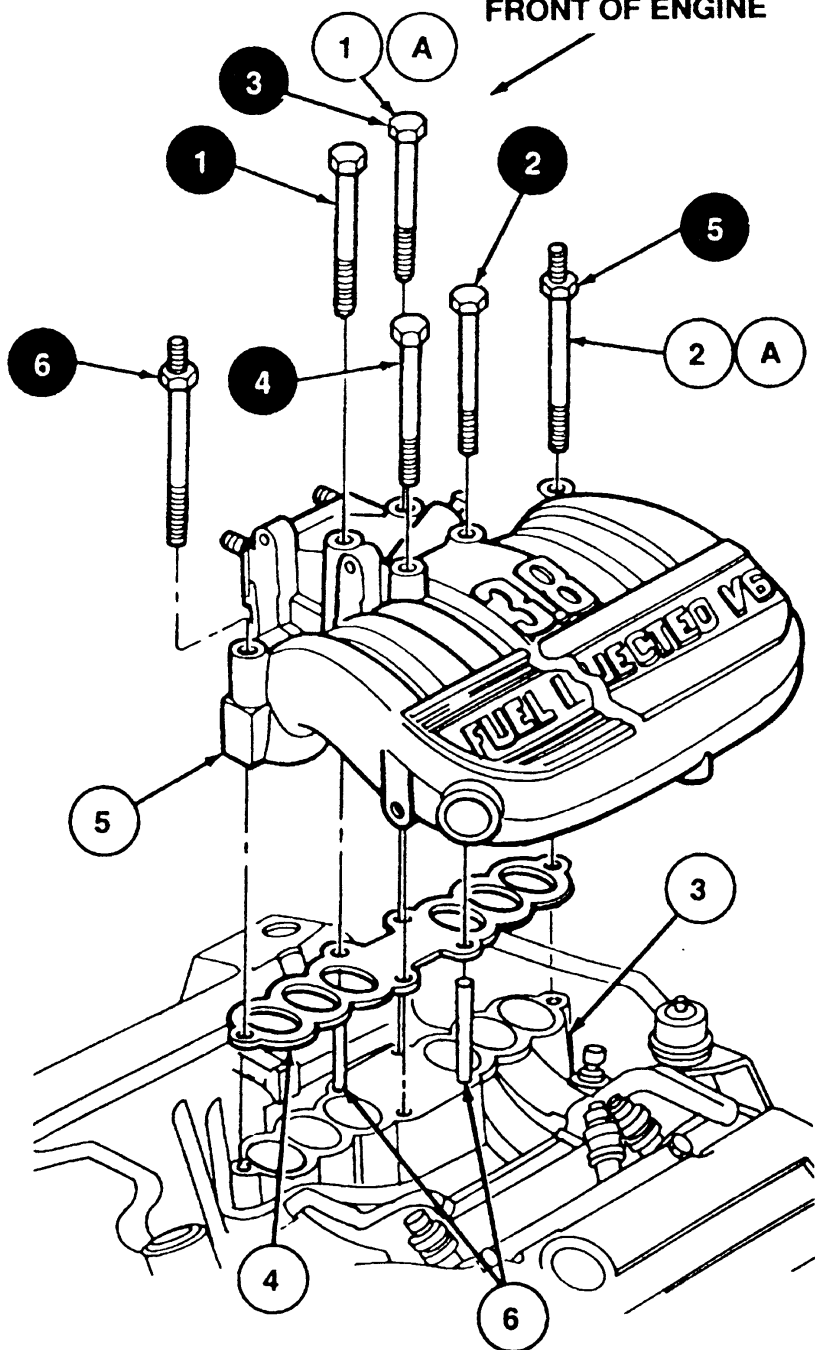

1 Bolt (4 req'd)

2 Stud (2 req'd)

3 Lower intake manifold

4 Intake manifold upper gasket

5 Upper intake manifold

6 Guide pin (2 req'd)

A Tighten in sequence in three steps:

10 Nm (8 lb.ft.)

20 Nm (15 lb.ft.)

32 Nm (24 lb.ft.)