

**LUBRICATE SEAL AND SEAL
MATING SURFACE WITH CLEAN
ENGINE OIL**

**CYLINDER BLOCK
6010**

**REAR MAIN
SEAL REPLACER
T82L-6701-A**

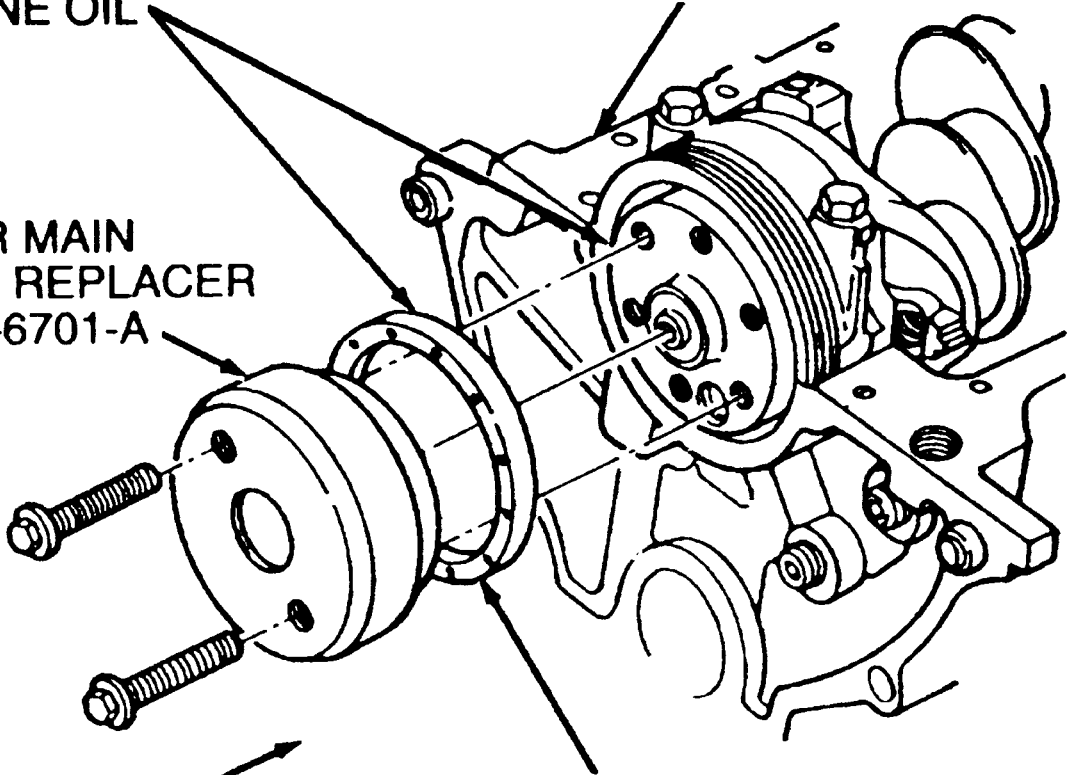

FRONT OF ENGINE

**CRANKSHAFT REAR OIL SEAL
6701 (INSTALL WITH SPRING SIDE
TOWARD ENGINE)**

**NOTE: REAR FACE OF SEAL MUST BE
WITHIN 0.508 mm (0.020 mm INCH) OF THE REAR
FACE OF THE BLOCK**