

3.0L SFI Engine

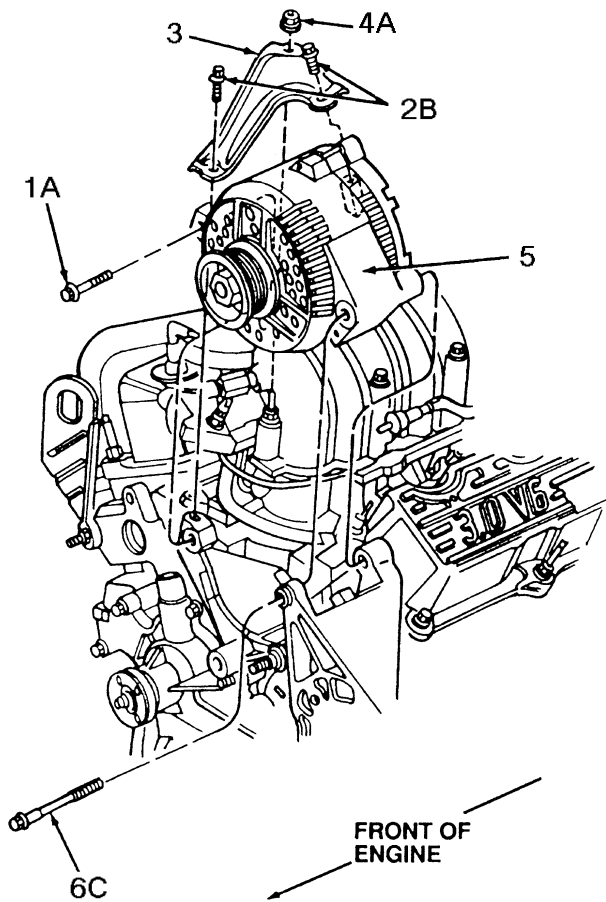

- 1A Mounting brace bolt
- 2B Bolt (2 req'd)
- 3 Generator brace
- 4A Nut and washer
- 5 Generator
- 6C Pivot bolt
- A Tighten to 20-30 Nm (15-22 lb.ft.)
- B Tighten to 8.5-11Nm (7-8 lb.ft.)
- C Tighten to 40-55 Nm (30-41 lb.ft.)

3.8L SFI Engine

