

TIMING POINTER

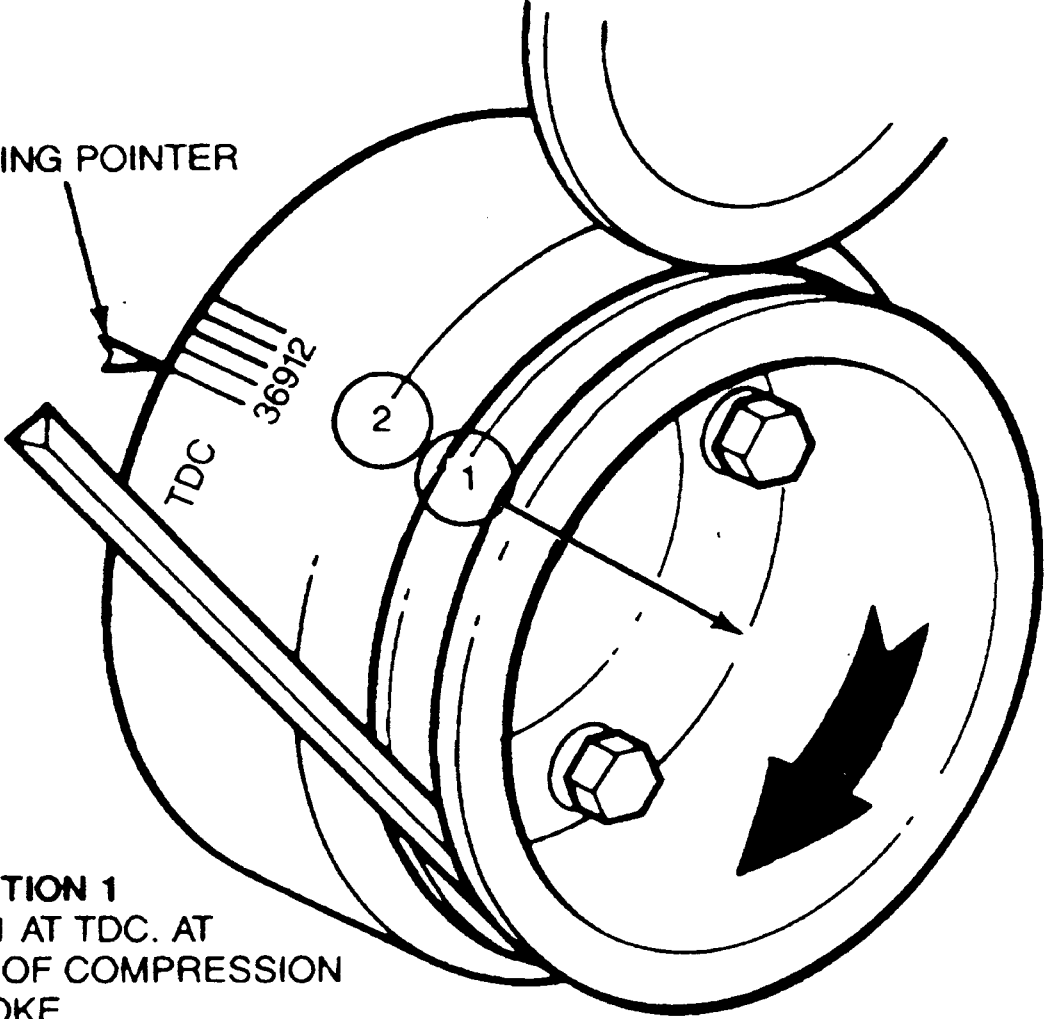

**POSITION 1**  
 NO. 1 AT TDC. AT  
 END OF COMPRESSION  
 STROKE

**POSITION 2**  
 ROTATE CRANKSHAFT  
 ONE REVOLUTION — 360  
 DEGREES

CYL. NO.	CRANKSHAFT POSITION	
	1	2
	<b>SET GAP OF VALVES NOTED</b>	
1	INT — EXH	NONE
2	EXH	INT
3	INT	EXH
4	EXH	INT
5	NONE	INT — EXH
6	INT	EXH