

TIMING POINTER

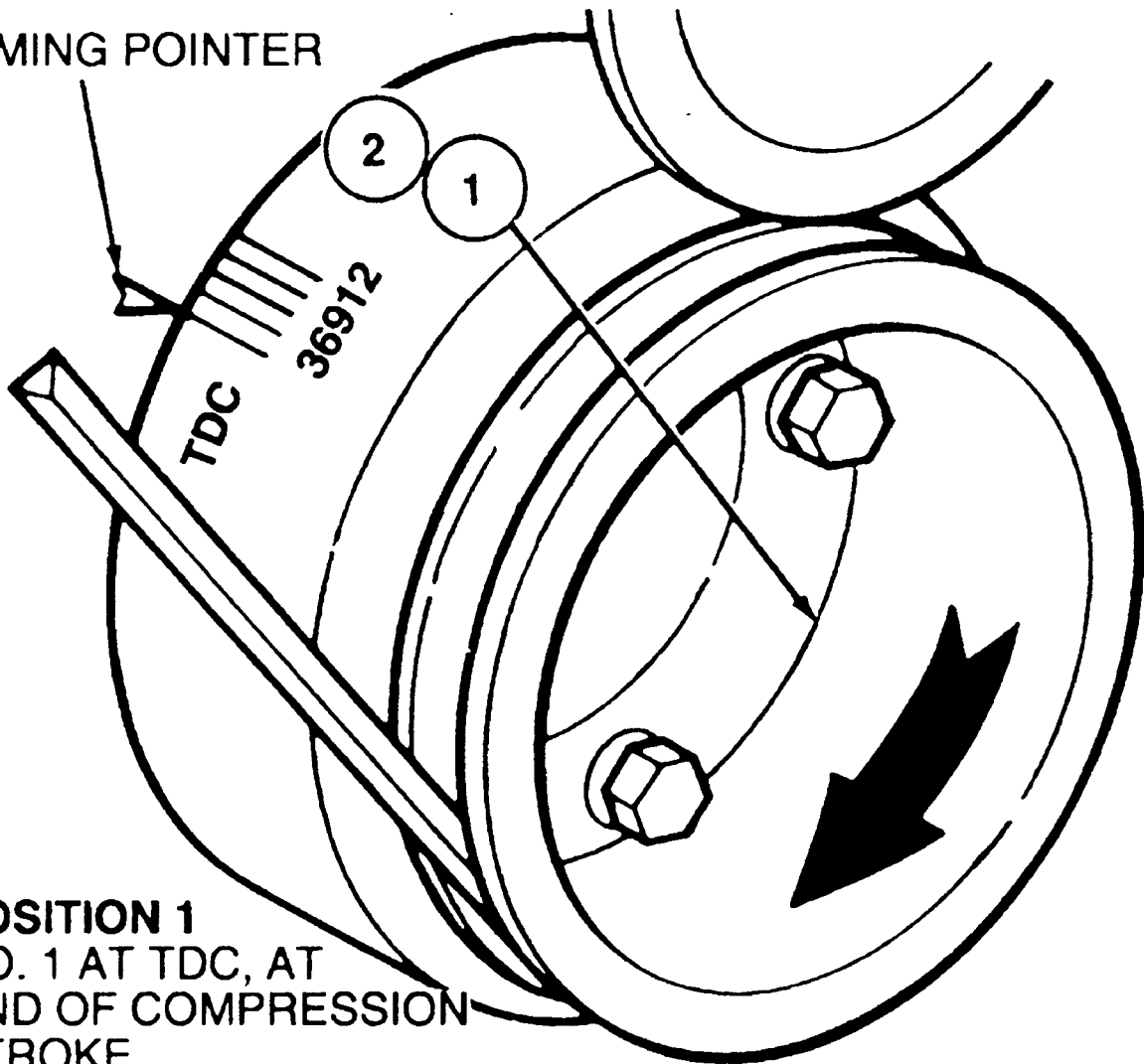

POSITION 1

NO. 1 AT TDC, AT
END OF COMPRESSION
STROKE

POSITION 2

ROTATE CRANKSHAFT
ONE REVOLUTION — 360 DEGREES