

FRONT OF ENGINE

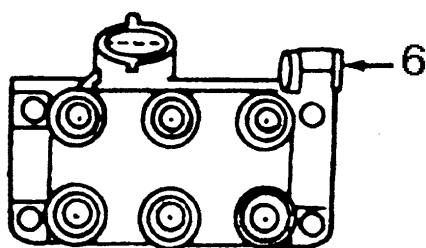
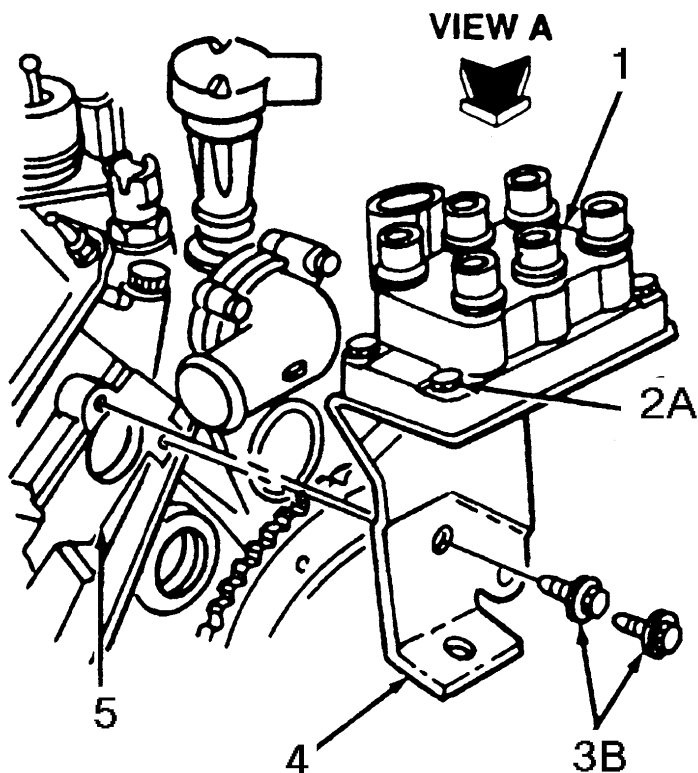

VIEW A

- 1 Ignition coil
- 2 Screw (4 req'd)
- 3 Bolt (2 req'd)
- 4 Ignition coil mounting bracket
- 5 Cylinder head (LH)
- 6 Radio ignition interference capacitor
- A Tighten to 4.5-7.0 Nm (44-61 lb.in.)
- B Tighten to 40-55 Nm (30-41 lb.ft.)